

Mid-Field Airpark Alternatives

July 6, 2021



RS&H



Introductions



Matthew Sykora, CM

Properties and Business Development, KCIA



Steven Domino, AAE

Project Manager, RS&H



Steven Derengowski, CM

Project Planner, RS&H

Agenda

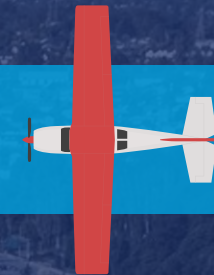

INTRODUCTIONS

PURPOSE AND STUDY AREA SUMMARY

PLANNING PARAMETERS

MID-FIELD AIRPARK CONCEPTS

NEXT STEPS





Resolve FAA Design Challenges



"Where do we relocate the 35 displaced aircraft to address a critical safety design deficiency?"



The Idea – Mid-Field Airpark



“How do we optimize the airpark to accommodate displaced aircraft in the short-term?”

Goals and Planning Objectives

*Correct nonstandard conditions at the Airport to maintain and improve the **safety of operations***

*Enhance the **efficiency of operations** of the Airport*

*The **immediate plan is compatible** with the Airport's long-term vision*

*Facility enhancements are developed through **strategic Capital Improvement Program (CIP) planning***

***Collaborate with key stakeholders** to understand unique perspectives*

*Future facilities are designed and **implemented for the users needs***



Mid-Field Airpark Site Considerations

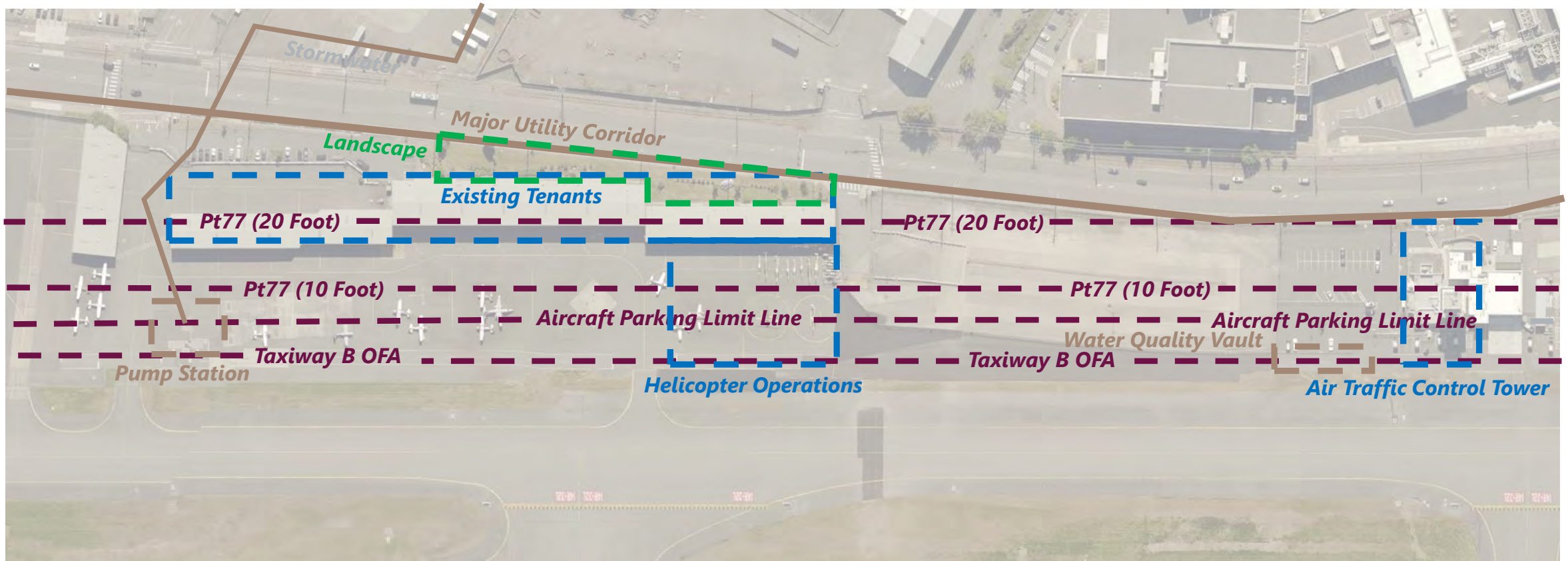

Airfield / Airspace
Design Standards



Tenant Leases
and Operations



Utility
Infrastructure



Environmental
Considerations



Defined Study Area

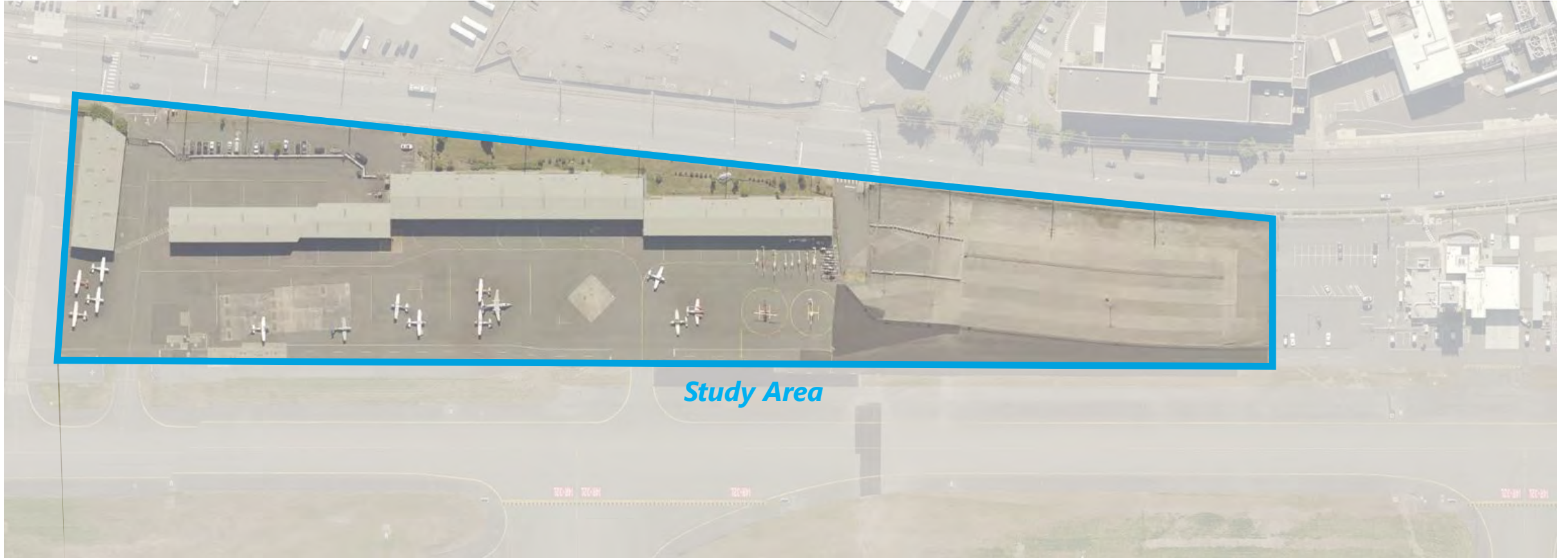

Your Input Is Valuable!

**Capacity to
Accommodate
Small GA
Aircraft**

Improve
Operational
Efficiencies

Utilities /
Ramp
Lighting

Self Service
Fuel
Facility

Wash Rack

Site Access

Run-up
Area

Concept Design Parameters

1

Meet FAA Design Standards

Existing nonstandard facilities corrected, and future facilities designed to standard

2

Tie-Down Designed for Cessna 172

Aircraft parking positions are provided for single engine aircraft

3

Level of Service

Maintain existing level of service and/or enhance the user experience

4

Short-Term Development Parameters

No major infrastructure improvements or acquire additional property

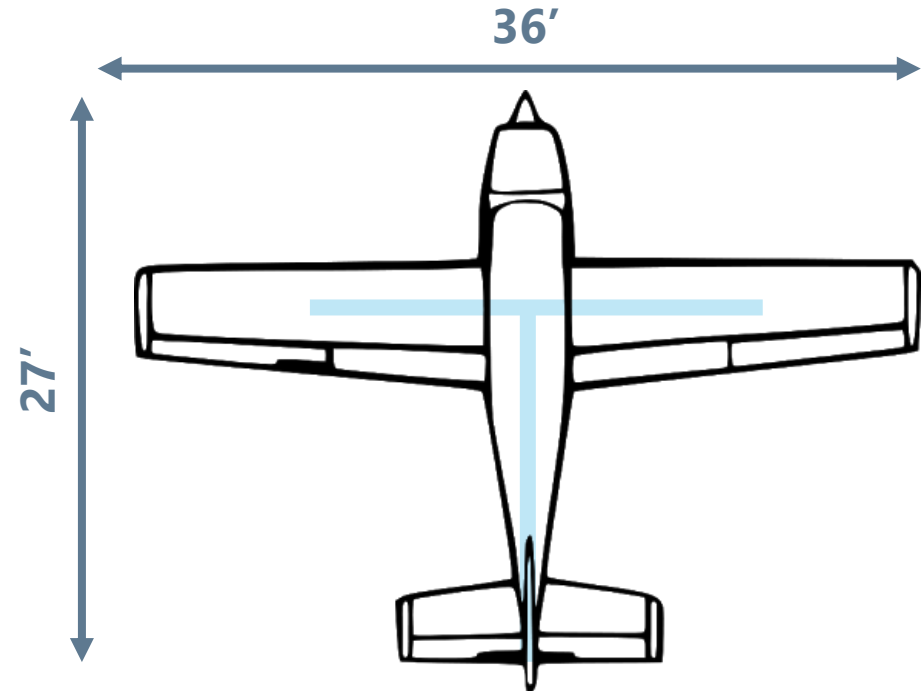

Concept Evaluation Criteria

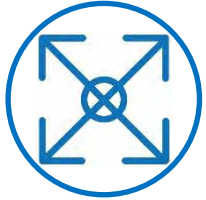

Capacity

Accommodating the greatest amount of parking positions



Support Facilities

Reserving land to develop facilities for tenant and users



Operational Efficiency

Reduce dead-end taxiways, multiple apron connectors and separation of aircraft



Constructability

Ease to implement and cost to construct

Location	Tie-Down Positions
NE Airpark	35 Displaced
Mid-Field Airpark	15 Existing
Total Capacity	50 Needed





Preliminary Mid-Field Concepts

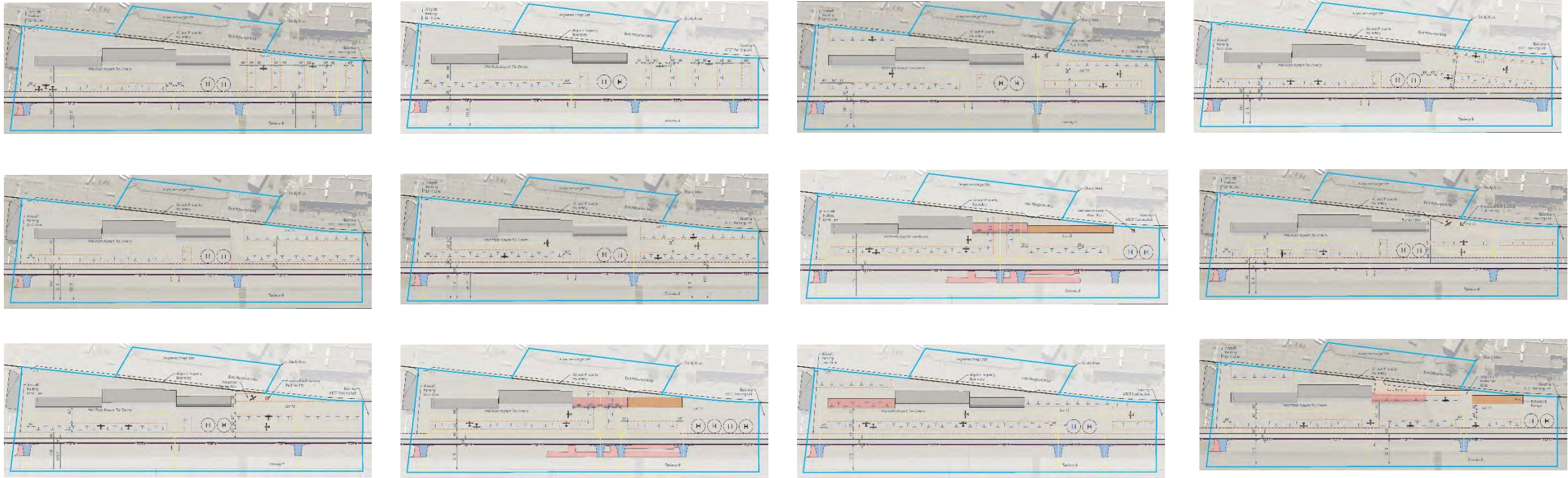

Started with 12 alternative concepts to address tenant needs



Preliminary Mid-Field Concepts

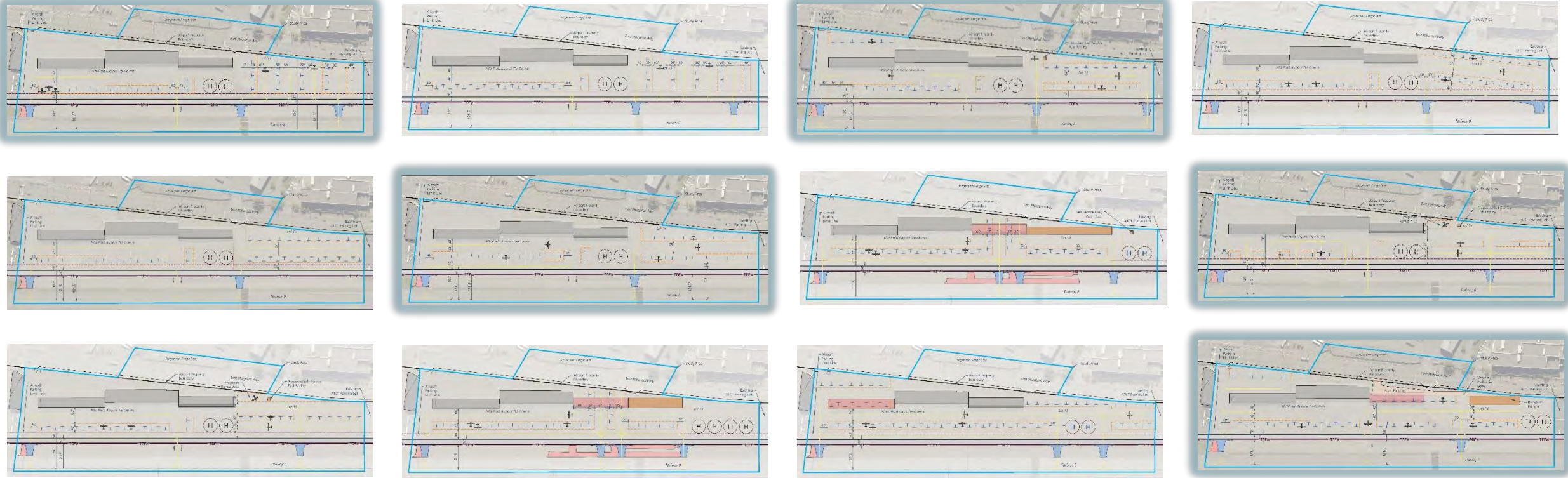

Discuss five alternative concepts for thoughts and considerations



Mid-Field Airpark Concept No.1

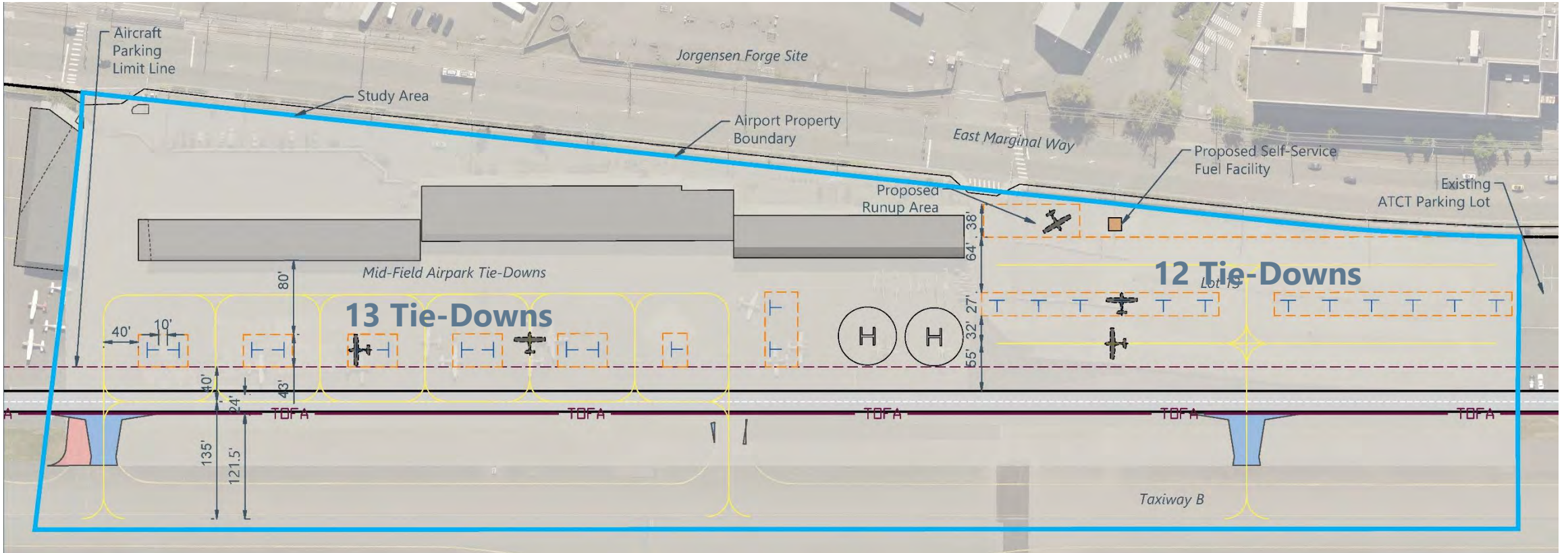

Evaluation Matrix



Capacity

Total Positions: 25
Net Capacity: -25



Support Facilities

Proposed Facilities: 2



Operational Efficiency

Entrance Taxilanes: 3
Dead End Taxilanes: 4



Constructability

Lease Impacts: None
Project Cost: \$\$



Mid-Field Airpark Concept No.2

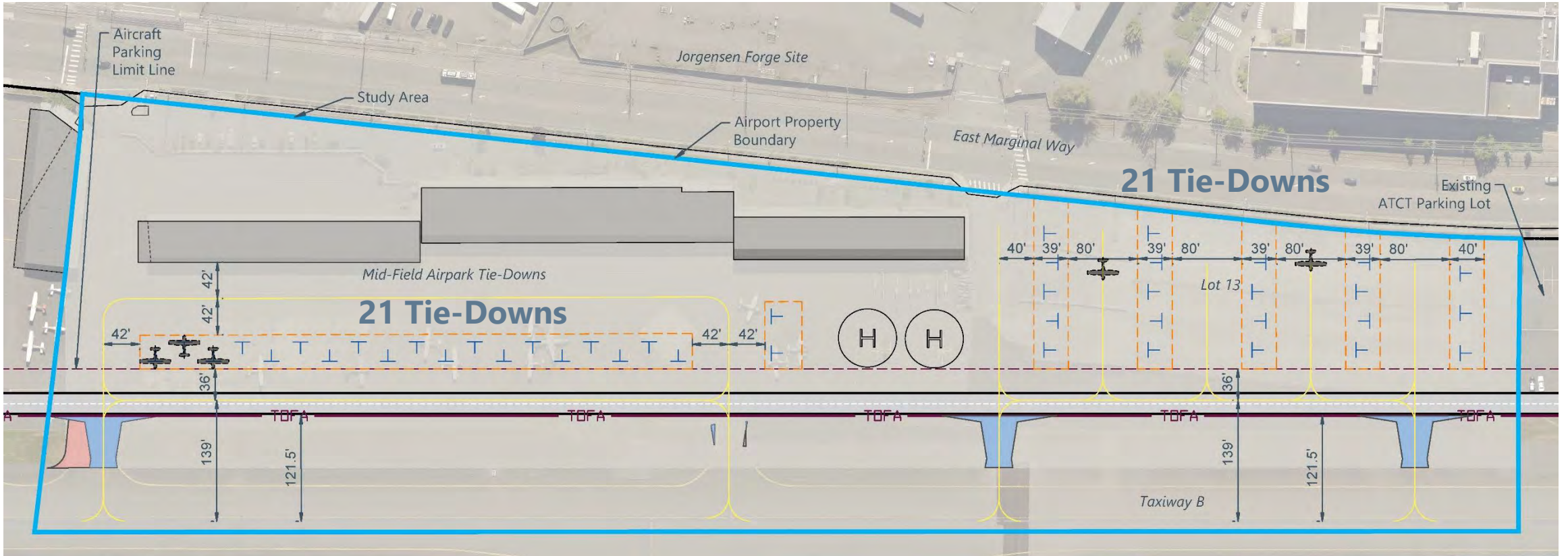

Evaluation Matrix

 <p>Capacity Total Positions: 42 Net Capacity: -8</p>	 <p>Support Facilities Proposed Facilities: 0</p>	 <p>Operational Efficiency Entrance Taxilanes: 4 Dead End Taxilanes: 5</p>	 <p>Constructability Lease Impacts: None Project Cost: \$\$</p>
--------------------------------------------------------------------------------------------------------------------------------------------------------	-------------------------------------------------------------------------------------------------------------------------------------------------	--------------------------------------------------------------------------------------------------------------------------------------------------------------------------------	---------------------------------------------------------------------------------------------------------------------------------------------------------------------



Mid-Field Airpark Concept No.3

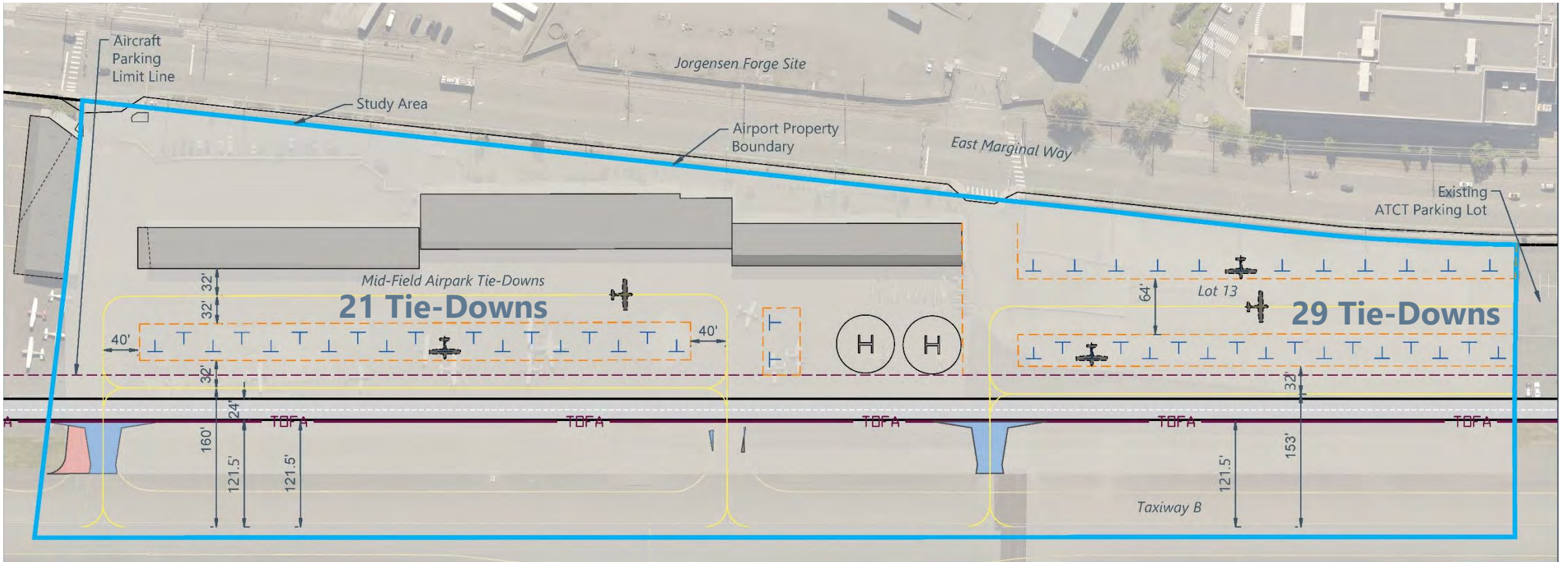

Evaluation Matrix

 **Capacity**
Total Positions: 50
Net Capacity: 0

 **Support Facilities**
Proposed Facilities: 0

 **Operational Efficiency**
Entrance Taxilanes: 3
Dead End Taxilanes: 2

 **Constructability**
Lease Impacts: None
Project Cost: \$



Mid-Field Airpark Concept No.4

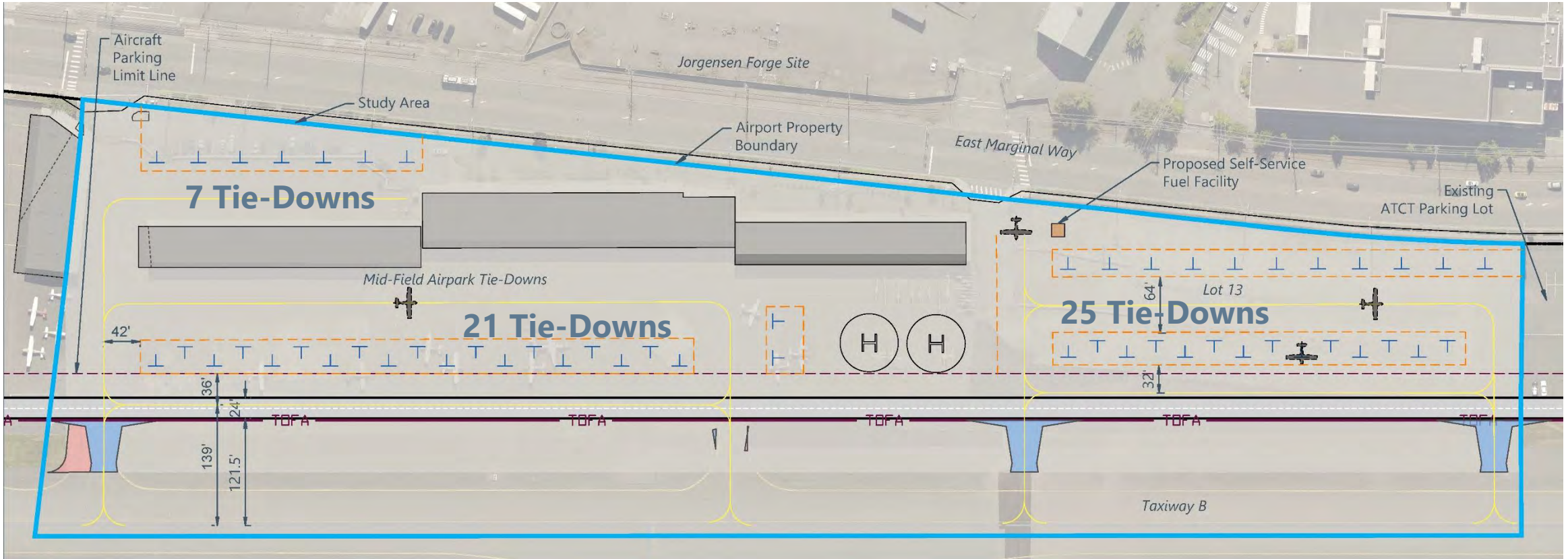

Evaluation Matrix



Capacity

Total Positions: 53
Net Capacity: +3



Support Facilities

Proposed Facilities: 1



Operational Efficiency

Entrance Taxilanes: 4
Dead End Taxilanes: 1



Constructability

Lease Impacts: None
Project Cost: \$\$



Mid-Field Airpark Concept No.5

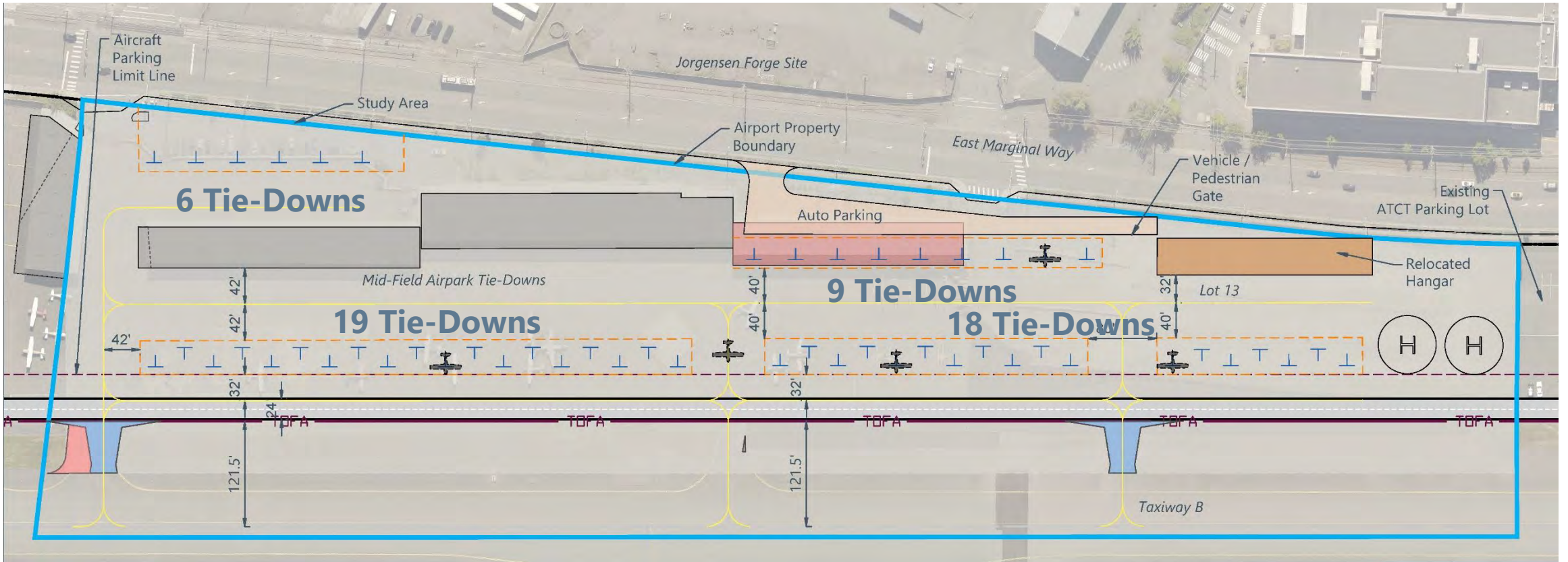

Evaluation Matrix



Capacity

Total Positions: 52
Net Capacity: +2



Support Facilities

Proposed Facilities: 0



Operational Efficiency

Entrance Taxilanes: 3
Dead End Taxilanes: 2



Constructability

Lease Impacts: Helicopters
Project Cost: \$\$\$



Mid-Field Airpark Concept No.6

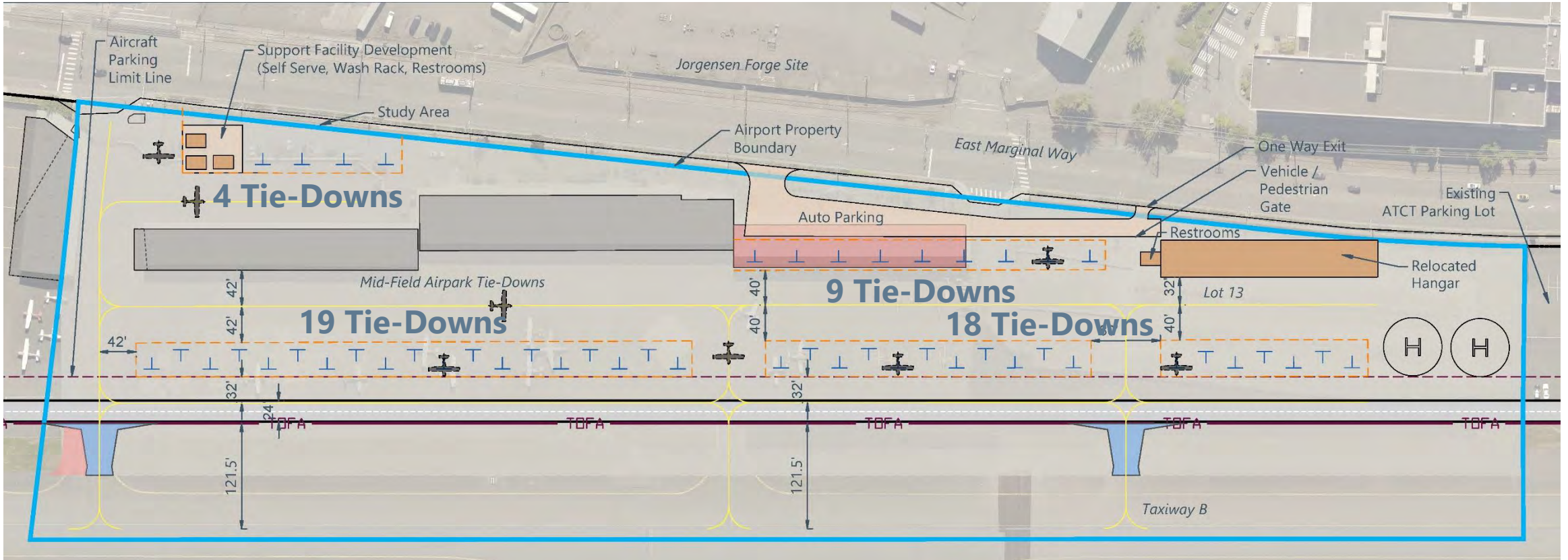

Evaluation Matrix



Capacity

Total Positions: 50
Net Capacity: +0



Support Facilities

Proposed Facilities: 3



Operational Efficiency

Entrance Taxilanes: 3
Dead End Taxilanes: 2







Constructability

Lease Impacts: Helicopters
Project Cost: \$\$\$

Mid-Field Airpark Concept Summary



Evaluation Matrix

	Concept No.1	Concept No.2	Concept No.3	Concept No.4	Concept No.5	Concept No.6
 Capacity	Net Capacity:-25	Net Capacity: -8	Net Capacity: 0	Net Capacity: +3	Net Capacity: +2	Net Capacity: 0
 Support Facilities	Proposed Facilities: 2	Proposed Facilities: 0	Proposed Facilities: 0	Proposed Facilities: 1	Proposed Facilities: 0	Proposed Facilities: 3
 Operational Efficiency	Entrance Taxilanes: 3 Dead End Taxilanes: 4	Entrance Taxilanes: 4 Dead End Taxilanes: 5	Entrance Taxilanes: 3 Dead End Taxilanes: 2	Entrance Taxilanes: 4 Dead End Taxilanes: 1	Entrance Taxilanes: 3 Dead End Taxilanes: 2	Entrance Taxilanes: 3 Dead End Taxilanes: 2
 Constructability	Lease Impacts: No Project Cost: \$\$	Lease Impacts: No Project Cost: \$\$	Lease Impacts: No Project Cost: \$	Lease Impacts: No Project Cost: \$\$	Lease Impacts: Yes Project Cost: \$\$\$	Lease Impacts: Yes Project Cost: \$\$\$

Feel Free to Reach Out

- » Mid-Field Airpark Development
- » Email: KCIACommunityOutreach@KingCounty.gov
- » Feedback due Tuesday, July 13th



Project Schedule



Investigation Phase (COMPLETED)

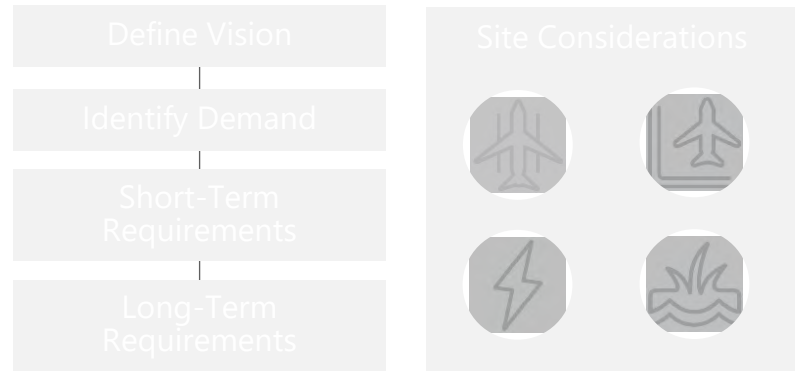

Solutions and Implementation Phase

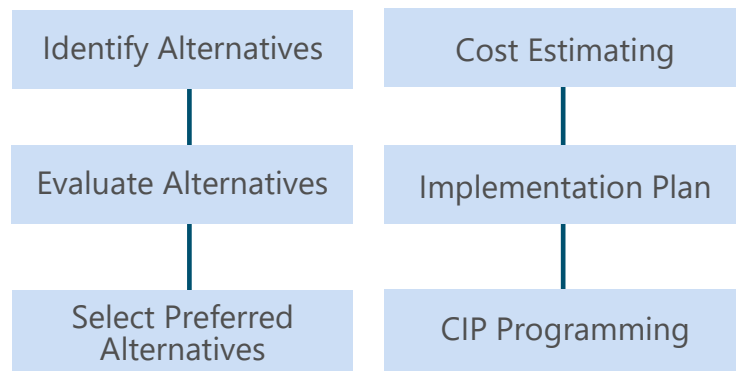

Documentation Phase

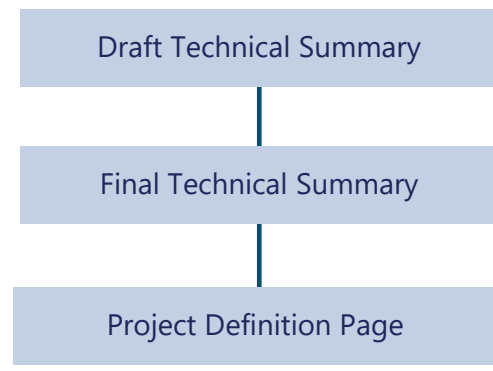

Key Milestones and Stakeholder Engagement

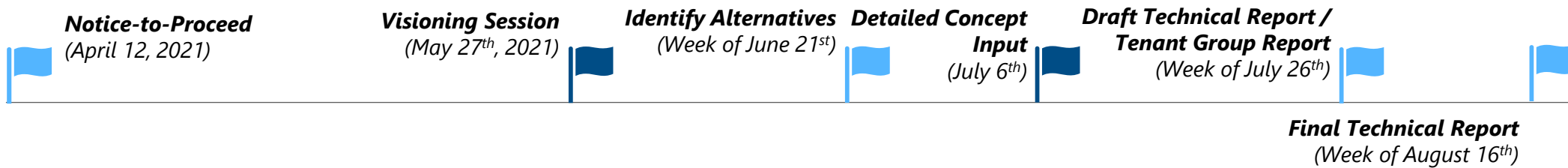

Legend:



Project Milestone



Stakeholder Engagement

Project Schedule

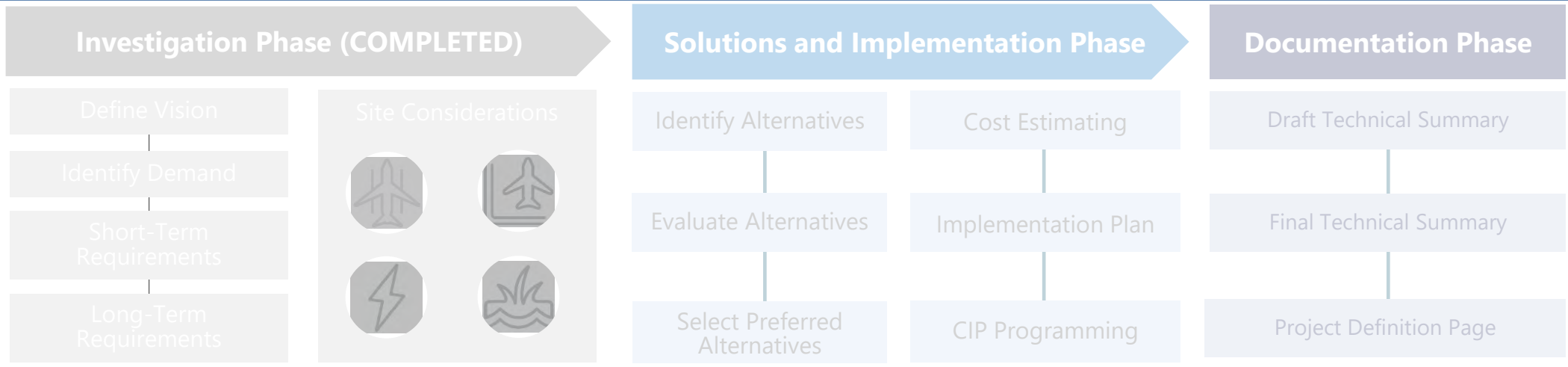

Key Milestones and Stakeholder Engagement

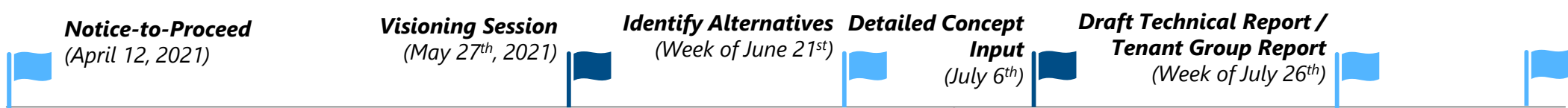

We Are Here →

Final Technical Report
(Week of August 16th)

Legend:



Project Milestone



Stakeholder Engagement